

FRESAS ROTATIVAS DE METAL DURO CON MANGO

NORDIFLEX

FORMA CILINDRICA A, SIN DENTADO FRONTAL

MANGO DIAMETROS 6 Y 8

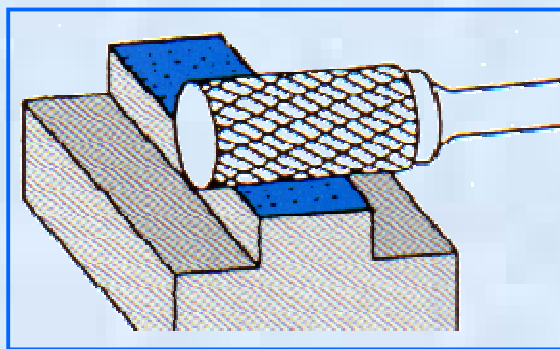
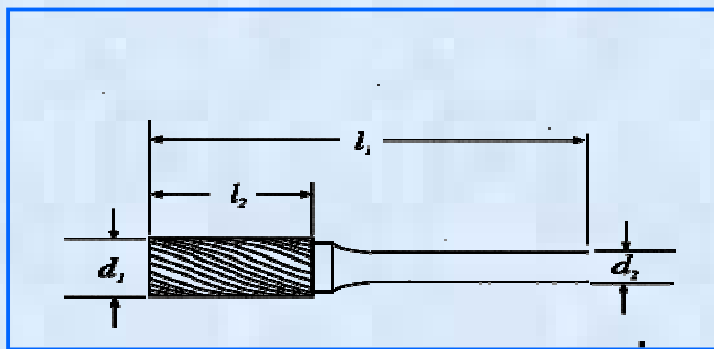

REF	D1 (mm)	L2 (mm)	L1 (mm)	D2 (mm)	DENTADOS DISPONIBLES						
					1	2	3	3SP	4	5	6
ZYA	3	12	56	6	*	*	*	*	*	*	*
ZYA	5	16	50	6	*	*	*	*	*	*	*
ZYA	6	16	50	6	*	*	*	*	*	*	*
ZYA	6	19	50	6	*	*	*	*	*	*	*
ZYA	6	25	50	6	*	*	*	*	*	*	*
ZYA	8	19	63	6	*	*	*	*	*	*	*
ZYA	9.5	25	69	6	*	*	*	*	*	*	*
ZYA	10	20	60	6	*	*	*	*	*	*	*
ZYA	11	25	69	6	*	*	*	*	*	*	*
ZYA	12.7	25	69	6 Y 8	*	*	*	*	*	*	*
ZYA	16	25	69	6 Y 8	*	*	*	*	*	*	*
ZYA	19	25	69	6 Y 8	*	*	*	*	*	*	*
ZYA	25	25	69	6 Y 8	*	*	*	*	*	*	*



OPCIONAL :

Ti-NAMITE

RECUBRIMIENTO ESPECIAL DISEÑADO PARA TODO TIPO DE APLICACIONES, QUE SEGÚN PRUEBAS REALIZADAS, ALARGA LA VIDA DE LA HERRAMIENTA HASTA OCHO VECES MAS QUE LAS FRESAS CONVENCIONALES.

NOTA : CONSULTAR PRECIOS Y CANTIDADES MINIMAS.



VIGO - TEL.:986.266249 FAX : 986.267005
www.sumicarol.com E-mail :info@sumicarol.com