



Bevelling system UZ 18 HARDWORKER

Maximum bevel width 18 mm / 0.71 in. Automatic feed.



UZ 18 HardWorker



Incredibly silent operation



3D adaptive system



Art. Nr. 1980 (3 Phase - 400 V)
Art. Nr. 1981 (3 Phase - 480 V)
Art. Nr. 1982 (3 Phase - 220 V)

3 BEVELERS
IN ONE

Resistant worm gearbox

Continuous setting of 15° - 50° angle

Powerful 3-phase engine 750 W

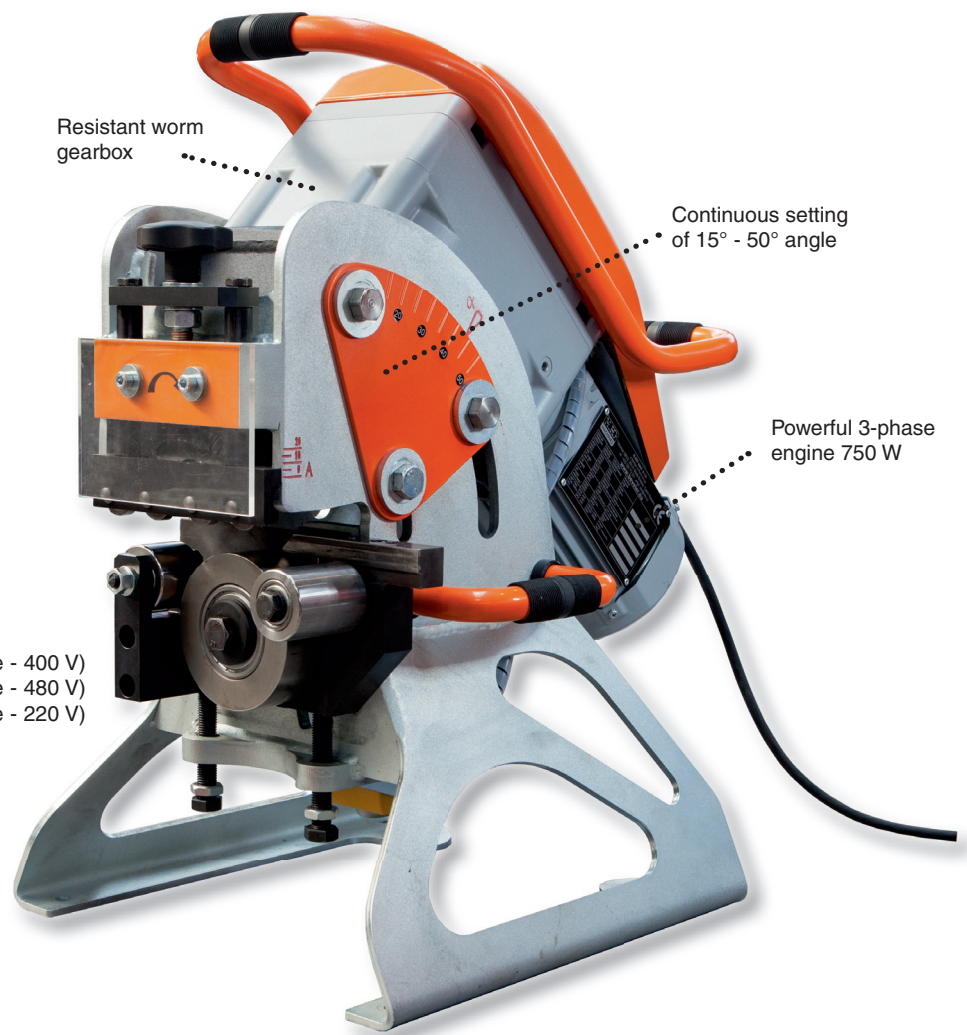

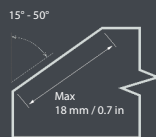

The UZ 18 Hardworker machine is one of the most powerful bevelling machines with the automatic feed on the market. It is suitable not only for workshops, but also for an assembly on-site. It has a continuous working angle adjustment system. Thanks to the special design of the drive system, the UZ 18 Hardworker is also suitable for tougher materials. The machine is equipped with the automatic feed. Working with UZ 18 Hardworker is therefore very comfortable.

- For steel (strength up to 600 MPa / 87 022 PSI), brass, copper and aluminium.
- For bevelling material with minimum dimensions - width 70 mm / 2.75 in, length 150 mm / 5.9 in, thickness 6 mm / 0.23 in.
- Thickness of bevelled material 6 to 40 mm / 0.23 to 1.57 in.
- The bevel angle is easily adjustable from 15° to 50° - smoothly, without the need to replace any part.
- The equipment is capable of performing double-sided bevelling (X, K) without the need for material handling.
- Easy connecting to the 3D Manipulator for easier operation and handling.
- The machine is equipped with an automatic feed.
- The possibility of stationary and mobile use.
- The machine works on large workpieces without any support.
- Smaller parts of the material are inserted directly into the machine.
- Discounted price when purchasing UZ 18 Hardworker together with the 3D Manipulator.

Technical data:

Max. bevel width:	18 mm / 0.71 in (600 MPa / 87 022 PSI)
Continuously adjustable angle:	15° - 50°
Thickness of bevel. material:	6 to 40 mm / 0.23 to 1.57 in
Engine:	750 W
Feed:	1,9 m/min. / 6.23 ft/min.
Weight:	110 kg / 242.5 lb
Dimensions (WxHxD):	438 x 719 x 644 mm 17.24 x 28.3 x 25.35 in

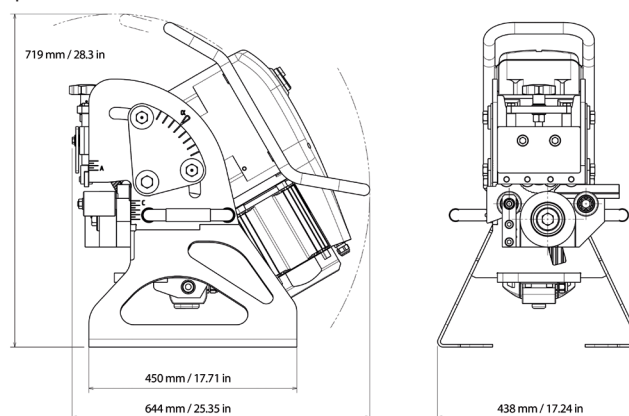

Included in price:

- Bevelling system UZ 18 Hardworker.
- Tools for an operator.
- Packet in a wooden crate.
- User manual.

Machine name:	Art. Nr.
BEVELLING SYSTEM UZ 18 HARDWORKER (3 Phase - 400 V)	1980
BEVELLING SYSTEM UZ 18 HARDWORKER (3 Phase - 480 V)	1981
BEVELLING SYSTEM UZ 18 HARDWORKER (3 Phase - 220 V)	1982

Accessories:	Art. Nr.
ECO cutting tool - suitable for conventional steel	2137
ECO cutting tool - suitable for conventional steel - 2 + 1 free set	2134
PVD cutting tool - suitable for tougher materials	2142
PVD cutting tool - suitable for tougher materials - 2 + 1 free set	1936
PREMIUM Cutting Tool - coated TiN, suitable for conventional steel	2136
3D Manipulator - allows to rotate the machine by 180° to create a two-sided bevel and facilitates the machine transport at the workplace	1930



Art. Nr. 2136



Art. Nr. 2134



Art. Nr. 2137



Art. Nr. 1936



Art. Nr. 1930





**Automatic feeding Beveling system UZ 18 HARDWORKER
+ 3D MANIPULATOR set Max. bevel width of 18 mm / 0.71 in.**

UZ 18 HardWorker + 3D Manipulator set



Silent operation



3D adaptive system



**3 BEVELERS
IN ONE**



**3 BEVELERS
IN ONE**

3D adaptive system compensates for the unevenness of the floor and enables positioning of the machine according to the situation at the workplace.



Rotary mechanism allows performing both-side beveling without any need for material handling.

Height adjustment of the machine position.

Quick-fastening machine system quick-connect

Art. Nr. 1983 (3 Phase - 400 V)
Art. Nr. 1984 (3 Phase - 480 V)
Art. Nr. 1985 (3 Phase - 220 V)

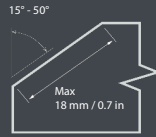

The UZ 18 Hardworker is one of the most powerful beveling machines with the automatic feed on the market. Suitable not only for workshops, but also for an assembly on-site. It is equipped with the continuous working angle adjustment system.

Thanks to the special design of the drive system, the UZ 18 Hardworker is also suitable for tougher materials. The machine is equipped with the automatic feed. Therefore, working with UZ 18 Hardworker is very comfortable.

Unique MANIPULATOR 3D - unique design of the manipulator offers the possibility of a simple turning of the beveling machine by 180° for performing the X, K double-sided bevel. No tools required to rotate. No need for material handling = significant time savings. The quick-connect system offers the option to connect and disconnect the UZ 18 Hardworker from the 3D Manipulator within seconds without the use of any tools. You will appreciate this in a situation where the 3D Manipulator cannot follow the machine due to the poor quality of the working floor. The machine is then able to travel along the material itself. The 3D manipulator system allows for the machine to adapt its working position to the actual workplace situation.

The UZ 18 Hardworker "floats" on a machined sheet metal and compensates for any floor unevenness or material deformation. The 3D manipulator also ensures convenient transport of the machine at the workplace.

The lifting mechanism allows easy adjustment of the working height of the machine.

Large castors guarantee comfortable overcoming of obstacles and unevenness.

Optional working with or without 3D Manipulator.

Possibility to use 3D Manipulator as a fixed workstation for small pieces processing or as a UZ18 Hardworker service bracket.

- The manipulator enables a quick and easy turning of the UZ 18 Hardworker by 180° to form the X- or K- shaped double-sided bevel. An operator does not need a crane to rotate the material - significant time savings at work.
- A unique clamping system allows the UZ 18 Hardworker to be clamped and then removed from the manipulator within a few seconds without the use of tools.
- The UZ 18 Hardworker "floats" in 3D MANIPULATOR and compensates for floor unevenness.
- 3D MANIPULATOR enables easy handling of the machine.
- The required height of the machine can be adjusted using the lifting device.
- The possibility to use the machine with without the 3D manipulator.
- The possibility to use the 3D Manipulator a stationary mode.
- Optional use of the Manipulator 3D as a stationary station.
- Optional use of the Manipulator 3D as a service station for the maintenance of the UZ 18 Hardworker.

Technical data:

Weight of the whole set: 204 kg / 449.7 lb
 Dimensions: 1010 x 745 x 1326 mm
 39.76 x 29.33 x 52.2 in

Included in price:

Beveling system UZ 18 HARDWORKER including the 3D MANIPULATOR
 Tools for an operator.
 Packet in a wooden crate.
 User manual.

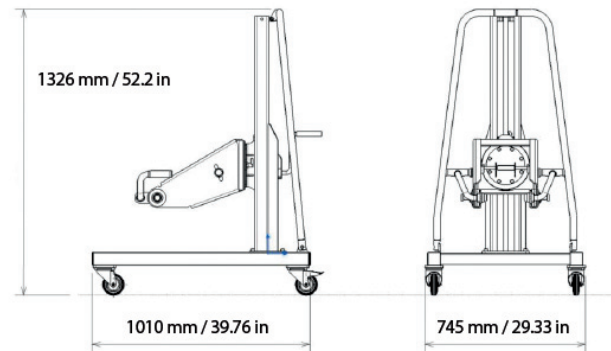

Name of machine:

Name of machine:	Art. Nr.
Beveling system UZ 18 HARDWORKER including the 3D MANIPULATOR (3 Phase - 400 V)	1983
Beveling system UZ 18 HARDWORKER including the 3D MANIPULATOR (3 Phase - 480 V)	1984
Beveling system UZ 18 HARDWORKER including the 3D MANIPULATOR (3 Phase - 220 V)	1985

